

 **ROSE BRAND**



ROSE BRAND

Rose Brand is pleased to present Soft-LED™, an innovative new product from Main Light Industries. A finely crafted combination of the latest fiber optic, computer and LED technologies, Soft-LED is the most dynamic and versatile product to hit the market yet! Soft-LED allows ultimate creative flexibility with the bonus of simple installation, handling and dismantling. Rose Brand's expertise in producing custom theatrical draperies paired with Main Light's extensive skills and knowledge in fiber optic and LED technology makes for a winning partnership! With long-standing experience in serving a variety of venues and applications, the Rose Brand-Main Light team ensures a perfect custom Soft-LED drop for even the most demanding and complex productions. Rose Brand's design specialists will work with you from the beginning, implementing your creative concept—making your vision a reality!



LED revolutionized.

See your designs re-imagined on our high quality black fabric that features our specially designed LED grid.



Unparalleled flexibility.

Get a good night's sleep...

Your custom light creation was a hit.

Your construction crew finished in record time.

And, you have no 11,000 pound video wall monster to deal with.

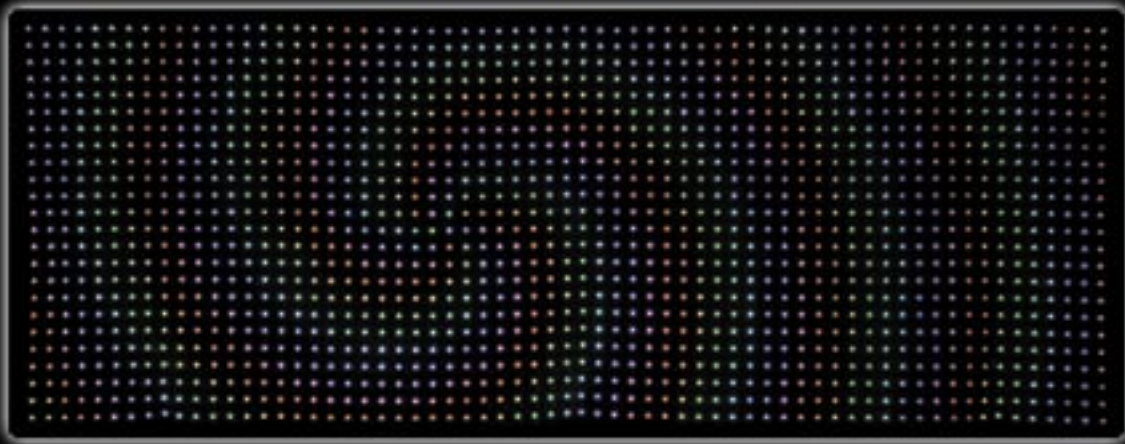

The image above shows a 16'x33' Soft-LED™ drapery at a distance of approximately 75 feet. This drapery features 8" LED spacing. Ask us about custom drapery—we can manufacture to your LED specifications!

Soft-LED™ is POWERFUL.

See your designs and graphics beautifully displayed on plush, high-quality, black drapery—the culmination of custom-designed LED grid presentation power, state-of-the-art fiber optics, and specialized processing technology.

The image below is a close-up illustration of the awesome power and flexibility you can achieve with Soft-LED™.

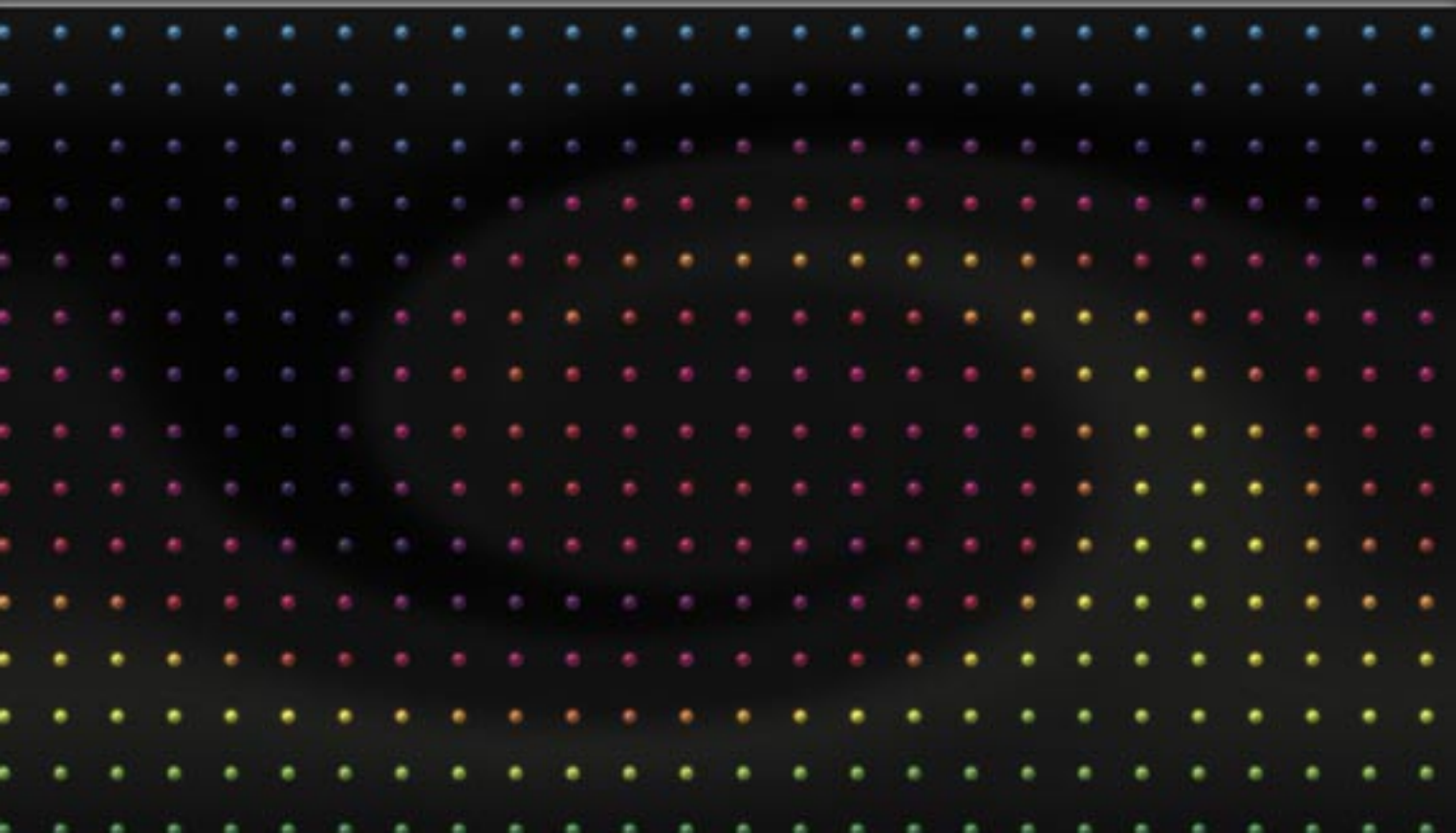

How does this puppy work?



It's about as easy as "R-G-B"! Actually, with your ingenuity and Rose Brand's Soft-LED™ Production Package, you and your team will be celebrating your newly found creative freedom—thrilled with your spectacular light design and pumped about the simple set up and tear down.

And here's how it's done...

1



Soft-LED™ starts with patented Chromacore® technology from Color Kinetics.

You use Color Kinetics® Light System Composer (LSC) software running on a PC to create your show. LSC can import a *.png sequence or images created by another application, such as Macromedia Flash.

Combine that with LSC's incredible built-in library of visual effects (e.g., rainbow spiral, color fade, and many others) and you're ready to upload to Color Kinetics Light System Engine...

2

Light System Engine (LSE) is an Ethernet-based hardware controller that stores and plays your show. In addition to storage and playback, LSE lets you assign ways to trigger playback (e.g., keypad inputs, DMX signals, time elapsing).



3

Finally, manage, monitor, and interact with your Soft-LED™ creation as it gloriously unfolds in front of you... and most importantly—your target audience.

Images along the right feature live shots of just a few of the infinite ways you can paint the Soft-LED™ drapery with light. Soft-LED™ will also accept moving video files!

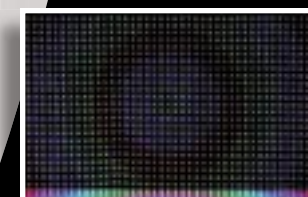
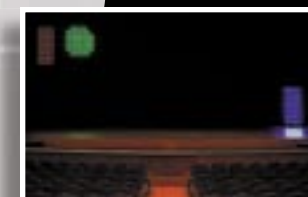
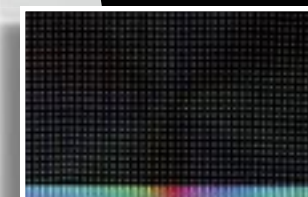
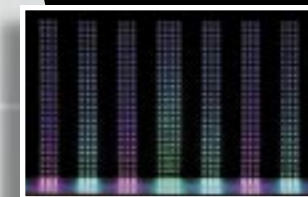

Elaborate, yet compact...

Soft-LED™ drapery not only meets your need for creative flexibility but also meets the universal demand for physical flexibility!

Soft-LED™ is delivered fully operational and ready to hang. It is capable of functioning as a dramatic and sizeable display when in use, yet is stunningly compact and lightweight and delightfully easy to disassemble at the end of the day.



In this example, a 2-man crew starts taking down two 16'x33' Soft-LED™ draperies at 11:00 P.M.

<<<



By 11:10 P.M., the 2-man crew is half-way to completion.

>>>



A mere 12 minutes later... and the crew is rolling up the light and flexible Soft-LED™ drapery.

<<<



At 11:24, Soft-LED™ is tossed into a compact 30"x50"x30" flight case; the lid is on; and the crew is ready to roll by 11:26!

>>>



How it all fits together

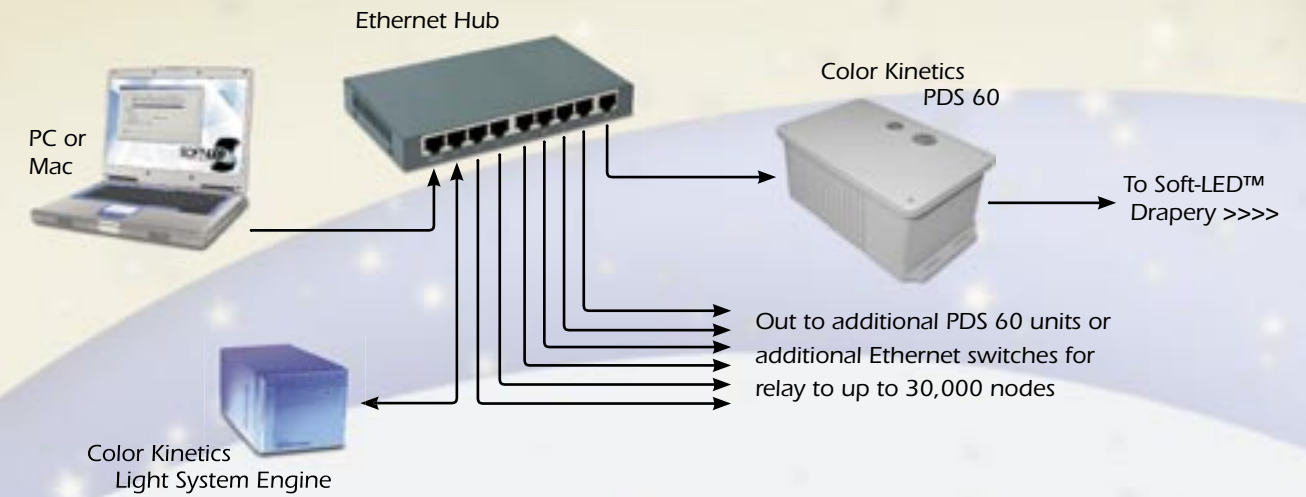

A peek inside the drapery

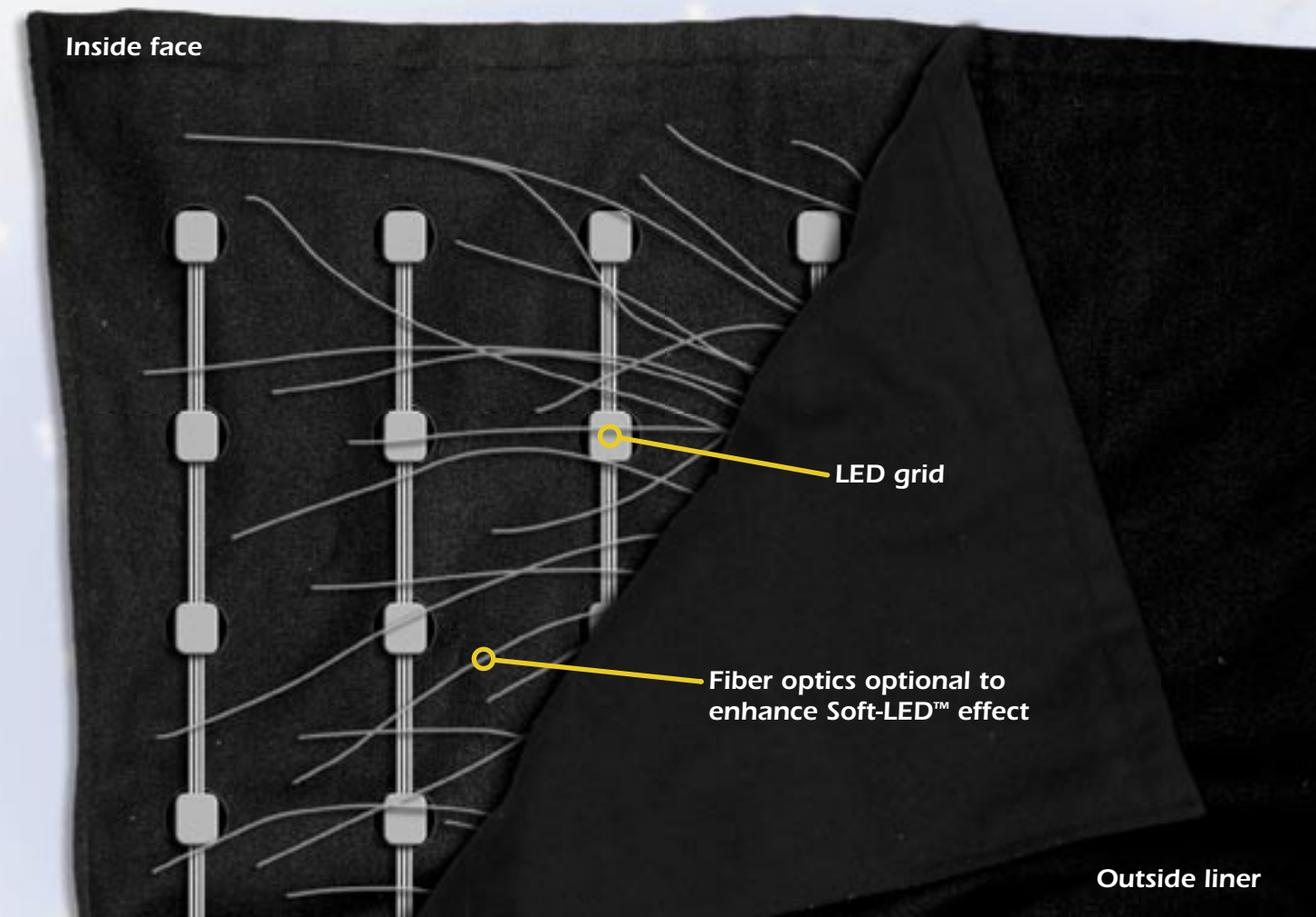

Soft-LED™ Specifications

Node Info:

- Tri-color surface mount LED
- Resolution:
 - High – 4" centers
 - Medium – 8" centers
 - Low – 12" centers
- IP66 outdoor rated nodes available
- Options:
 - Frosted lenses
 - Clear lenses

Drapery Material:

- Face: 22 oz Encore IFR
- Liner: Black IFR

Weight for Medium Resolution (subject to change):

- .26 lbs per sq ft with fiber optic
- .2 lbs per sq ft without fiber optic

Power Supply:

- Comes in waterproof IP66 enclosure
- Each power supply can run up to 100 nodes
- Connects via Ethernet for data
- Options:
 - Theater Box, 5" deep x 10⁵/₈" high x 3' long
 - Touring Rack, 16 space rack, 25" deep
 - Multi-pin connectors
 - 24-port 10/100 Ethernet switch
 - Rack-mount UPS
 - Fiber Channel Card

Software:

- Color Kinetics Light System Control software for Windows XP or Mac OS X 10.2 or higher (computer supplied by customer)
- Web interface available for logging and backup
- Options:
 - Rack-mount computer

Hardware:

- Color Kinetics Light System Manager (Specialized Linux Distribution) on a Pentium 4 system mounted in small enclosure can run up to 30,000 nodes
- Options
 - 2 space rack-mount PC version
 - 8 button serial keypad remote
 - 8 button Ethernet keypad remote
 - DMX/Midi interface
 - Video interface

Specifications for 16'1" x 33'5" Rental Curtain with Medium Resolution:

- Weight with fiber: 140 lbs
- LED Nodes: 1200
- Power Supplies: 12
- Power Consumption with LSE: 750 Watts
- Touring Rack with:
 - Rack-mount Light System Engine
 - Multi-pin connector
 - 1500AVR UPS
 - Rack-mount power supplies
 - Rack-mount 10/100 switch

Patent Pending

 **ROSE BRAND**

75 Ninth Avenue
New York, NY 10011
800.223.1624
212.242.7565 Fax

10616 Lanark Street
Sun Valley, CA 91352
800.360.5056
818.505.6293 Fax

www.rosebrand.com

